

LOC	DIST	REVISIONS			
P	LTR	DESCRIPTION	DATE	DWN	APVD
AF	50	AR1	REVISED PER ECR-14-004075	24MAR2014	NK RL

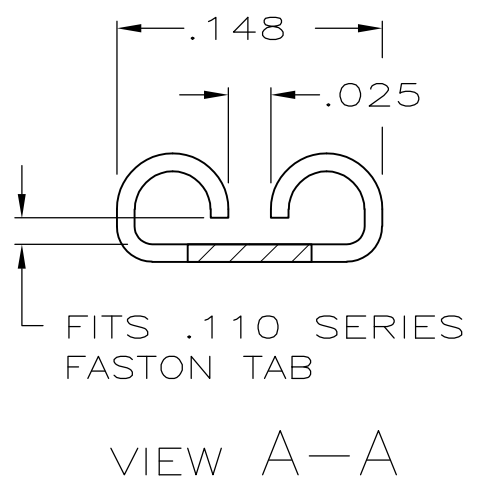

- 1 CONTINUOUS STRIP ON REELS.
- 2 MATING TAB THK IS $.032 \pm .001$.
- 3 FINISH LEAD-FREE, MATTE TIN OVER NICKEL

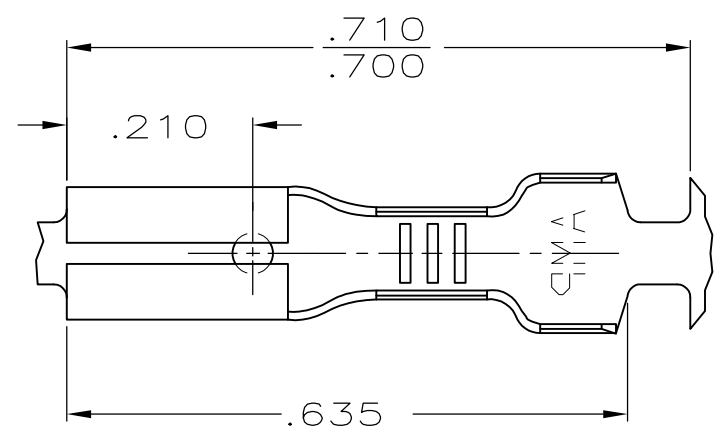
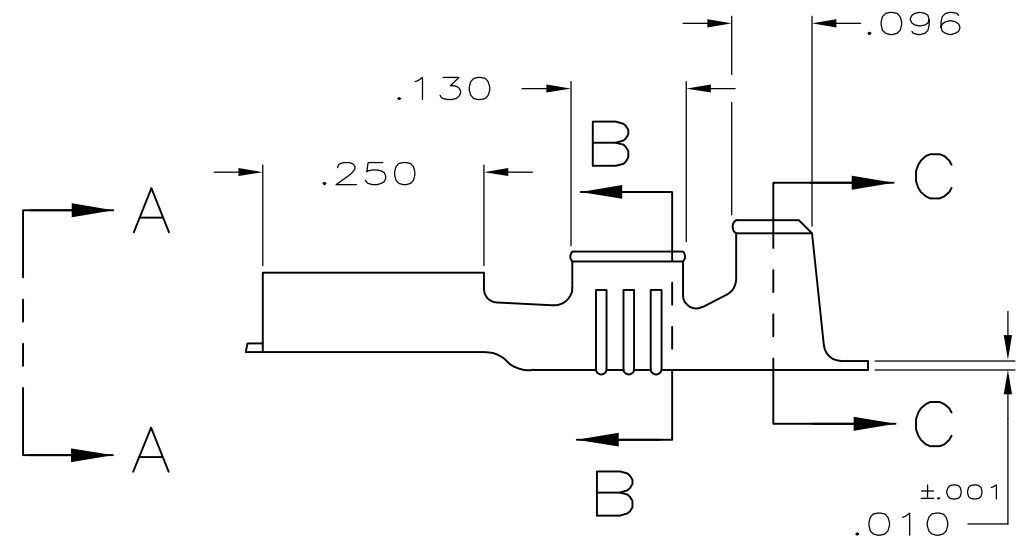
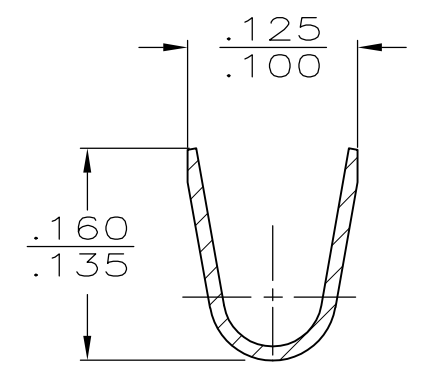
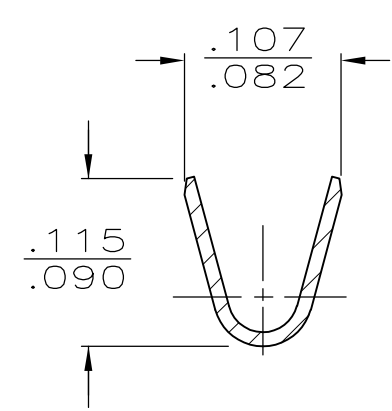

.060-.100 DIA	#22-#18 AWG	3	60197-3
		PLAIN	60197-2
		PRE-TIN	60197-1
INSUL RANGE	WIRE SIZE	FINISH	PART NO

THIS DRAWING IS A CONTROLLED DOCUMENT.		DWN JR RUTH 6/23/87	STE TE Connectivity														
DIMENSIONS: mm[INCHES]		CHK G YETTER 6/23/87															
TOLERANCES UNLESS OTHERWISE SPECIFIED:		APVD C MEYERS 6/23/87	NAME RECEPTACLE, FASTON,™ .110 SERIES														
<table border="1"> <tr><td>0 PLC</td><td>± -</td></tr> <tr><td>1 PLC</td><td>± -</td></tr> <tr><td>2 PLC</td><td>± -</td></tr> <tr><td>3 PLC</td><td>± .015</td></tr> <tr><td>4 PLC</td><td>± -</td></tr> <tr><td>ANGLES</td><td>± -</td></tr> </table>		0 PLC	± -	1 PLC	± -	2 PLC	± -	3 PLC	± .015	4 PLC	± -	ANGLES	± -	PRODUCT SPEC -	SIZE A3	CAGE CODE 00779	DRAWING NO C-60197
0 PLC	± -																
1 PLC	± -																
2 PLC	± -																
3 PLC	± .015																
4 PLC	± -																
ANGLES	± -																
MATERIAL BRASS	FINISH SEE TABLE	APPLICATION SPEC -	RESTRICTED TO -	CUSTOMER DRAWING													
		WEIGHT -	SCALE 5:1	SHEET 1 OF 1	REV AR1												